

DCC brake module LEC001021

1 Overview

- Module equivalent to the BM1 module ref 22600 from Lenz.
- Allows the gradual stop and restart of trains running in a DCC environment.
- Maximum current of 3A
- ABC Breaking module for DCC **only compatible with a few decoders** (see section 4)
- 3 screw holes for easy mounting.

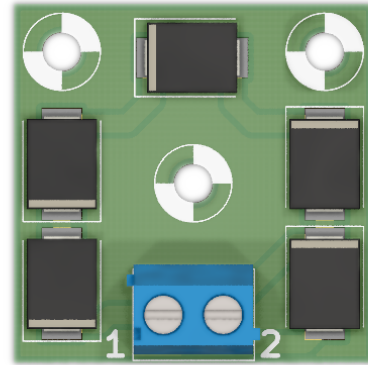

2 Applications

- Automatic stop of a convoy at the foot of a signal.
- Push-pull operation.
- Blocks systems - HO scale.
- Automatic stop when the railway switch is not properly set.
- Automatic stop at the station.

3 Technical specifications

Specification	Unit	Value
Maximum continuous current	A	3
Maximum peak current (8.3 ms)	A	100
Dimensions	mm	30 * 30 * 13
Weight	g	5

Table 1: Specifications

4 Compatibility

 **Warning:** this module only works in digital mode and is only compatible with decoders that support ABC technology. The table 2 shows a non-exhaustive list of decoders supporting ABC technology.

This module is recommended for the HO scale. For the N scale, use the **LEC001020**.

Brand	Compatible decoder	Manufacturer reference
Lenz	Gold maxi	10440
	GOLD+ NEM652	10433-01
	GOLD+ mini NEM651	10411-01
	GOLD+ mini wired	10410-01
	Silver+ NEM652	10331-01
	Silver+ direct	10330-01
	Silver+ 21	10321-01
	Silver+ Plux12	10312-01
	Silver+ mini NEM651	10311-01 / 10311-02
	Silver+ mini wired	10310-01
Standard+ V2	10231-02	
ESU	LokPilot V4 / V5	All LokPilot V4 and V5
	LokSound V4 / V5	All LokSound v4 and V5
zimo	Miniature decoders	MX620, MX620N, MX620R, MX620F MX618N18, MX621, MX621N, MX621R MX621, FMX622, MX622R, MX622F, MX622N
		MX63, MX63R, MX63F, MX63T MX623, MX623R, MX623F, MX623P12 MX630, MX630R, MX630F, MX630P16
	Thin HO decoders	MX64, MX64R, MX64F, MX64T
	High power HO decoders	MX64H, MX64HR, MX64HF, MX64V MX631, MX631R, MX631F, MX631D, MX631C MX632, MX632R, MX632D, MX632C, MX632V MX632W, MX632VD, MX632WD MX633, MX633R, MX633F, MX633P22
		MX648, MX648R, MX648F, MX648P16 MX646, MX646R, MX646F, MX646N, MX646L
	Miniature sound decoders	MX645, MX645R, MX645F, MX645P16 MX645P22, MX644D, MX644C
	HO sound decoders	
	tOm (trainOmatic)	LOKCOMMANDER II

Table 2: Compatible decoders

5 Usage

By generating an asymmetry in the DCC signal, this module allows compatible decoders to detect areas of slowdown or shutdown and react accordingly.

There are two steps to setting up this module: installation and wiring of the module and configuration of the decoder(s).

5.1 Installation and wiring of the module

Note: For optimal and safe operation, the wiring of this module must be done with a wire having a minimum section of 0.2mm².

The module must be wired as shown in the figure 1. The switch is optional. It allows the module to be shunted to manually restart the stopped train.

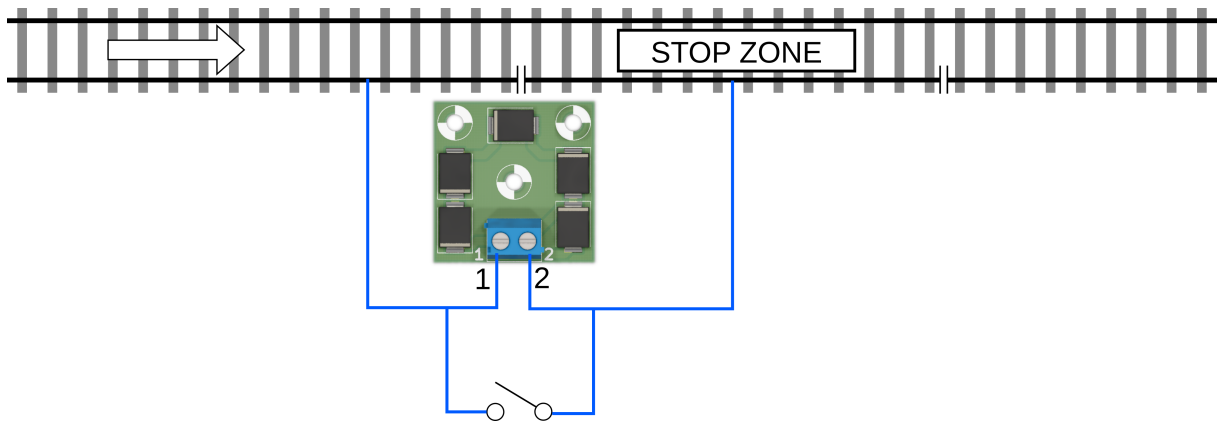



Figure 1: Wiring diagram for a stop zone controlled by a switch.

- When the switch is open, or there is simply no switch, a signal will be emitted on the right rail of the stop zone, and any machine with a compatible and configured decoder will perform a stop procedure.
- When the switch is closed, no signal will be transmitted at the stop area, so no train will stop in the area. If a train was stopped in the stop area, it will restart gradually.

 **Note :** The switch can be replaced by a relay, limit switch, or any other system with at least 1A breaking capacity.

5.2 Decoder configuration

To detect the ABC signal emitted by this module, the decoders must be configured accordingly. The table 3 shows the CVs used to enable or modify the decoder's behaviour towards the ABC signal.

5.2.1 Determining the decoder

If you know the type of decoder in your machine, go to the next section.

To identify the brand of your decoder, you need to read the value of CV8.

Brand	Lenz	ESU	Zimo	tOm
Value of CV8 identifying the manufacturer	99	151	145	78

This table is not exhaustive, you will find a more complete list on the following link:
<https://www.jmri.org/xml/XSLT/pages/DecoderId.html>

5.2.2 ABC activated

 In any case, you will have to activate the ABC function of the decoder so that your trains can react to the signal emitted by this module.

Brand	Lenz	ESU	Zimo	tOm
ABC braking, voltage higher on the right hand side	CV51 = 2 (bit 1)	CV27 = 1 (bit 0)	CV27 = 1 (bit 0)	CV27 = 1 (bit 0)
ABC braking, voltage higher on the left hand side	-	CV27 = 2 (bit 1)	CV27 = 2 (bit 1)	CV27 = 2 (bit 1)
Activation of ABC in both directions of travel	CV51 = 6 (bits 1 + 2)	CV27 = 3 (bits 0 + 1)	CV27 = 3 (bits 0 + 1)	CV27 = 3 (bits 0 + 1)

5.2.3 Testing the ABC signal detection

At this point, test if the machine detects the ABC stop signal.

 In some configurations, the machine may not detect the ABC stop signal correctly. Some decoder brands offer additional settings to address this issue.

Brand	Lenz	ESU	Zimo	tOm
ABC Detection threshold	-	CV134 = (4 ≤ val ≤ 32)	CV134 = (101 ≤ val ≤ 114)	CV141 = (8 ≤ val ≤ 16)
Compensation for ABC signal sensing error	-	CV102 = (0 ≤ val ≤ 255)	CV142 = (0 ≤ val ≤ 255)	-

5.2.4 Activate constant braking distance

The constant braking distance is the setting that allows a train to stop within a certain distance, regardless of its speed. Although not mandatory, this setting is strongly recommended for optimal operation.

Brand	Lenz	ESU	Zimo	tOm
Activation of constant braking distance	CV51 += 1 (bit 0)	-	CV140 = 1	CV27 += 128 (bit 7)
Braking length	CV52 = (0 ≤ val ≤ 255)	CV254 = (1 ≤ val ≤ 255)	CV141 = (0 ≤ val ≤ 255)	CV64 = (1 ≤ val ≤ 255)

 The '+=' sign means that the value given in the table must be added to the one previously set.

5.2.5 CV Summary for ABC

Brand	CV	bit	Function
Lenz	51	0	Activation of the constant braking distance
		1	ABC activated
		2	ABC direction-dependency deactivated
		3	Activate push-pull operation with intermediate stop
	4	Activate push-pull operation without intermediate stop	
	52	-	Braking length at constant braking distance activated
ESU	27	0	ABC braking, voltage higher on the right hand side
		1	ABC braking, voltage higher on the left hand side
	102	-	Compensation for ABC signal sensing error
	134	-	ABC Detection threshold
	254	-	Constant braking distance
zimo	27	0	ABC braking, voltage higher on the right hand side
		1	ABC braking, voltage higher on the left hand side
	134	-	ABC Detection threshold
	140	0	Activation of the constant braking distance function
	141	-	Constant braking distance
	142	-	Compensation for ABC signal sensing error
tOm	27	0	ABC braking, voltage higher on the right hand side
		1	ABC braking, voltage higher on the left hand side
	7		Activation of the constant braking distance function
	64	-	Constant braking distance
	141	-	ABC Detection threshold

Table 3: CV for ABC

Note : if the maneuver mode or the reduced run mode is activated, the decoder will ignore the ABC signals.

6 Dimensions

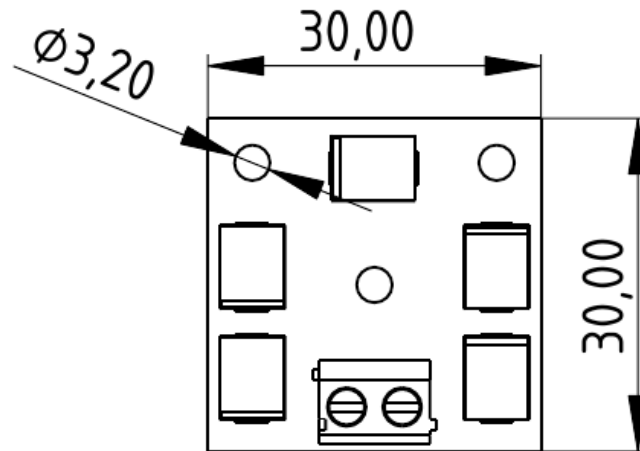

Figure 2: Dimensions of the module (all dimensions in mm).

7 Contact and support

For further information, please contact contact@lectix.fr.

8 Revision History

Revision	Date	Author(s)	Description
1.0.0	01.05.21	TFC	Creation of the document
1.0.1	14.05.22	TFC	Adding compatible decoders
1.1.0	30.05.22	TFC	Added clarification in section 5.2